



Note: Not all standards and approvals apply to all Part Numbers,

Product overview

Product	Optical Smoke Detector
Part No.	ORB-OP-12001-APO
Product	Optical Smoke Detector with flashing LED
Part No.	ORB-OP-12003-APO

Product information

Optical smoke detectors have always been recognised as good detectors for general use. They are regarded as particularly suitable for smoldering fires and escape routes.

The performance of Orbis optical detectors is good with black as well as with white smoke. In this respect Orbis detectors are different from traditional optical smoke detectors which perform far better in white smoke than in black.

Orbis Optical Smoke Detectors are also designed to reduce significantly the incidence of false alarms through over-sensitivity to transient phenomena.

Orbis Optical Smoke Detectors are recommended for use as general purpose smoke detectors for early warning of fires in most areas.

- Improved sensitivity to black smoke
- Compensation for build-up of dirt
- Extra confirmation of smoke before an alarm signal is given

All data is supplied subject to change without notice. Specifications are typical at 24 V, 25°C and 50% RH unless otherwise stated.

www.cagsfiresystem.in

Technical Data

Detection principle	Photo-electric detection of light scattered by smoke particles over a wide range of angles.	
Sampling frequency	Once every four seconds	
Operating voltage	8.5 V dc to 33 V dc	
Supply Wiring	Two wire supply, polarity sensitive	
Maximum polarity reversal	200 ms	
Power up time	< 20 seconds	
Minimum 'detector active' voltage	6 V	
Power-up surge current at 24 V	95 µA	
Average quiescent current at 24 V	95 µA	
Alarm current	12 V	20 mA
	24V	40 mA
Alarm load	600 Ω	
Holding voltage	5V-33V	
Minimum holding current	8 mA	
Minimum voltage to light alarm LED	5 V	
Alarm reset voltage	< 1 V	
Alarm reset time	One second	
Alarm indicator	Integral indicator with 360° visibility	
Remote output LED (-) characteristic	1.2 kΩ connected to negative supply	
Operating and storage temperature	-40°C to +70°C	
Humidity (no condensation or icing)	0% to 98% RH	
Effect of atmospheric pressure on optical sensor	None	
Effect of windspeed	None	
IP Rating	IP44	
Standards and approvals	EN54-7, CPR, LPCB, VdS, BOSEC, SBSC, FG, CSIRO	
Dimensions	97 mm diameter x 31 mm height	
Weight	75 g	
Materials	Housing: White flame retardant polycarbonate Terminals: Tin plated stainless steel	
Compliance*	Part No. ORB-OP-12001-APO - CPR, LPCB, VdS, BOSEC, SBSC, FG Part No. ORB-OP-12003-APO - CPR, LPCB, BOSEC, FG, CSIRO	

All information in this document is given in good faith but Apollo Fire Detectors Ltd cannot be held responsible for any omissions errors. The company reserves the right to change the specifications of products at any time and without prior notice.



DIMENSION

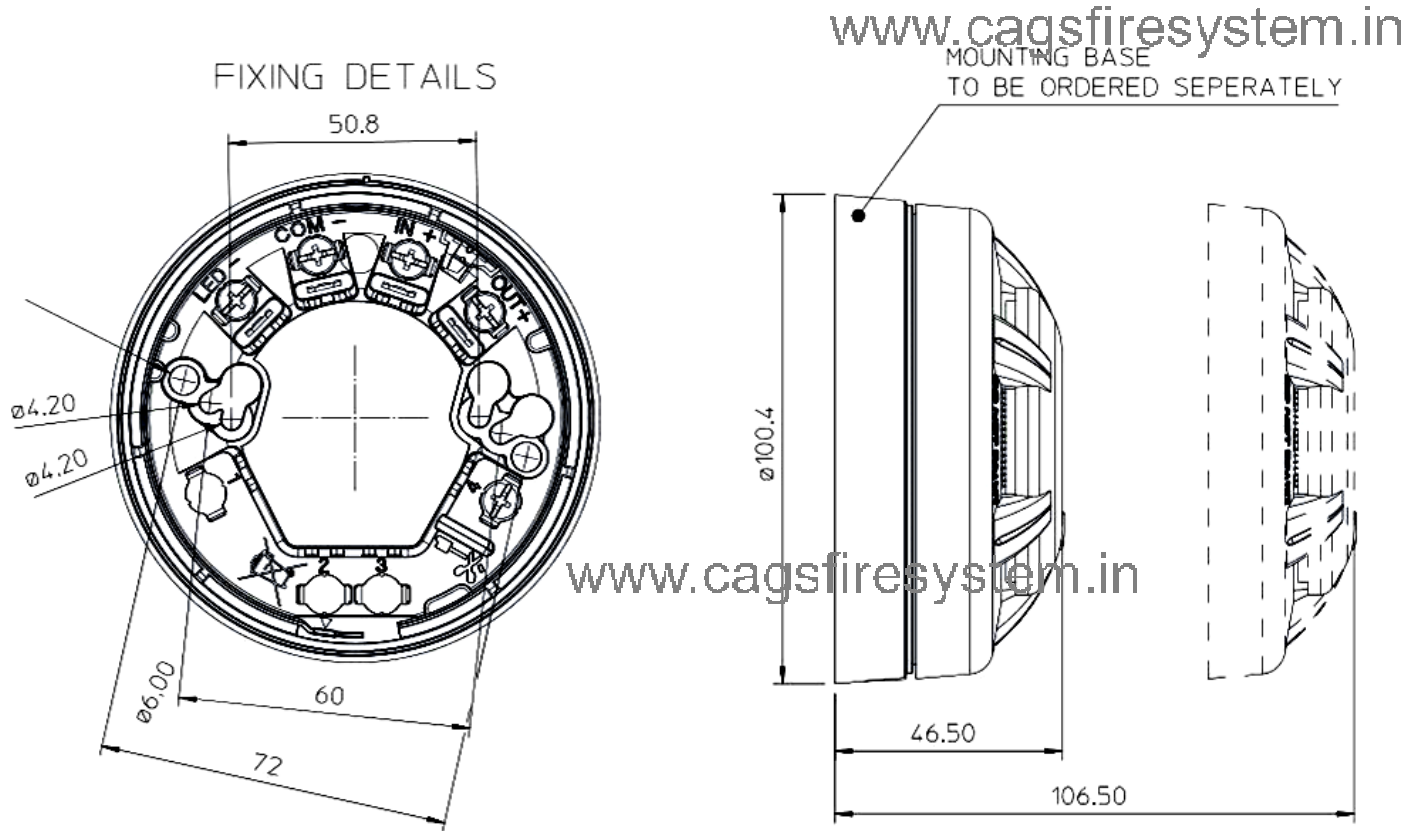

Orbis detectors - LED status

Feature	Description	Red LED status	Yellow LED status
StartUp™	Confirms that the detectors are wired in the correct polarity	Flashes once per second	No flash
FasTest™	Maintenance procedure, takes just four seconds to functionally test and confirm detectors are functioning correctly	Flashes once per second	No flash
DirtAlert™	Shows that the drift compensation limit has been reached	No flash	Flashes once per second in StartUp (Stops flashing when StartUp finishes)
SensAlert™	Indicates that the sensor is not operating correctly	No flash	Flashes every four seconds (Flashes once per second in StartUp)
Normal operation	At the end of StartUp and FasTest (without flashing LED as standard)	No flash	No flash
Flashing LED version	Detectors red LED flashes in normal operation (at the end of FasTest)	Flashes every four seconds	No flash

www.cagsfiresystem.in