



Note: Not all standards and approvals apply to all Part Numbers.

Product overview

Product	Orbis Heat Detector	Orbis Heat Detector with flashing LED
	Part No.	Part No.
Class A1R	ORB-HT-11001-APO	ORB-HT-11013-APO
Class A1S	ORB-HT-11166-APO	ORB-HT-11167-APO
Class A2S	ORB-HT-11002-APO	ORB-HT-11014-APO
Class BR	ORB-HT-11003-APO	ORB-HT-11015-APO
Class BS	ORB-HT-11004-APO	ORB-HT-11016-APO
Class CR	ORB-HT-11005-APO	ORB-HT-11017-APO
Class CS	ORB-HT-11006-APO	ORB-HT-11018-APO

Product information

The Orbis Heat Detector range incorporates six heat detector classes to suit a wide variety of operating conditions in which smoke detectors are unsuitable.

The European Standard EN 54-5 classifies heat detectors to the highest ambient temperature in which they can safely be used without risk of false alarm. The classes are identified by the letters A to C (Class 1 is sub-divided into A1 and A2). In addition to the basic classification, detectors may be identified by a suffix to show that they are rate-of-rise (suffix R) or fixed (static) temperature (suffix S) types.

- All heat detectors in the Orbis range are tested as static or rate-of-rise detectors and are classified as A1R, A2S, BR, BS, CR or CS.

All data is supplied subject to change without notice. Specifications are typical at 24 V, 25°C and 50% RH unless otherwise stated.

Technical Data

Detection principle	Measurement of heat by means of a thermistor
Sampling frequency	Once every two seconds
Supply voltage	8.5 V dc to 33 V dc
Supply Wiring	Two wire supply, polarity sensitive
Maximum polarity reversal	200 ms
Power up time	< 20 seconds
Minimum 'detector active' voltage	6 V
Power-up surge current at 24 V	95 μ A
Average quiescent current at 24 V	95 μ A
Alarm current 12 V	20 mA
24V	40 mA
Alarm load	600 Ω
Holding voltage	5V-33V
Minimum holding current	8 mA
Minimum voltage to light alarm LED	5 V
Alarm reset voltage	< 1 V
Alarm reset time	One second
Alarm indicator	Integral indicator with 360° visibility
Remote output LED (-) characteristic	1.2 k Ω connected to negative supply
Operating and storage temperature	-40°C to +70°C
Humidity (no condensation or icing)	0% to 98% RH
Effect of atmospheric pressure on optical sensor	None
Effect of wind speed	None
IP Rating	IP44
Standards and approvals	EN54-5, CPR, LPCB, VdS, BOSEC, SBSC, FG and CSIRO
Dimensions	97 mm diameter x 36 mm height
Weight	70 g detector
Materials	Housing: White flame-retardant polycarbonate
Terminals:	Nickel plated stainless steel

All information in this document is given in good faith but Apollo Fire Detectors Ltd cannot be held responsible for any omissions or errors. The company reserves the right to change the specifications of products at any time and without prior notice.



DIMENSION

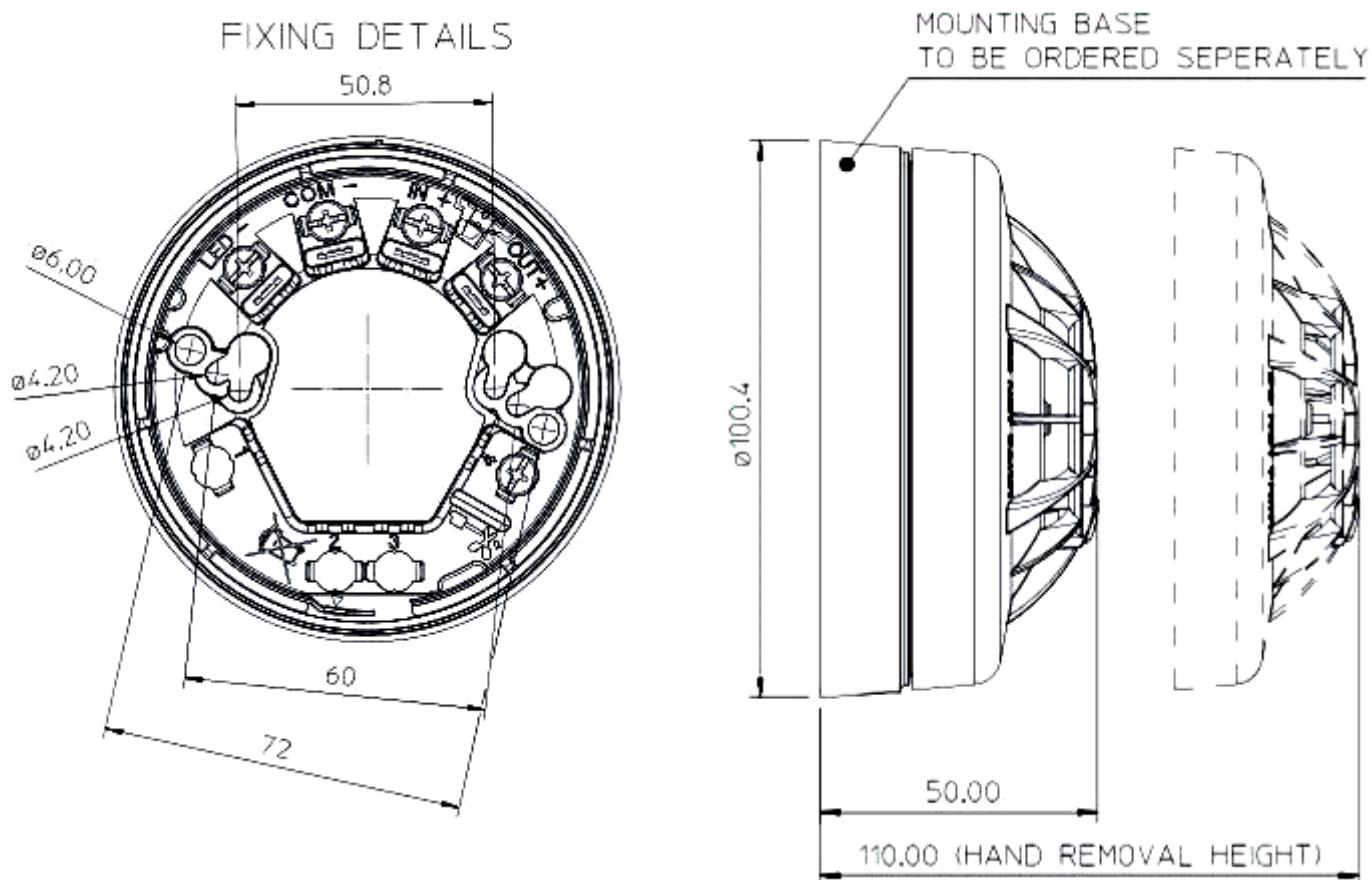

Orbis detectors - LED status

Feature	Description	Red LED status	Yellow LED status
StartUp™	Confirms that the detectors are wired in the correct polarity	Flashes once per second	No flash
FasTest™	Maintenance procedure, takes just four seconds to functionally test and confirm detectors are functioning correctly	Flashes once per second	No flash
DirtAlert™	Shows that the drift compensation limit has been reached	No flash	Flashes once per second in StartUp (Stops flashing when StartUp finishes)
SensAlert™	Indicates that the sensor is not operating correctly	No flash	Flashes every four seconds (Flashes once per second in StartUp)
Normal operation	At the end of StartUp and FasTest (without flashing LED as standard)	No flash	No flash
Flashing LED version	Detectors red LED flashes in normal operation (at the end of FasTest)	Flashes every four seconds	No flash